

WSK-MLT MULTIFUNCTION WALL SWITCH

- INSTALLATION AND OPERATING INSTRUCTIONS -

Introduction

The WSK-MLT multifunctional wall switch is designed to control flame height, blower speed, and auxiliary functions on your gas fireplace. For models equipped with the Intellifire system (IPI), the cold climate function can control the pilot flame as well. The wall switch is equipped with thermostat functions which can automatically control the temperature in the room in which it is installed. The wall switch interfaces with both intermittent and standing pilot systems. An auxiliary function provides 110-120 VAC source for added features the fireplace may have installed. Electrical ratings for the control box are 110 VAC, 60 Hz, and is required for operation of this device.

Installation precautions

This remote is tested and safe when installed in accordance with this installation manual. It is your responsibility to read all instructions before starting installation and to follow these instructions carefully during installation. Do not install any components that may be damaged. Do not modify, disassemble, or substitute any of the components included with this kit. Installation of this unit must be done by a qualified service technician.

Placement of this wall switch may affect performance or accuracy of the automatic (thermostat) control. An assessment of the space should be done prior to installation for optimal performance. See the installation instructions section I for recommendations.

NOTE: The electrical junction box provided with the fireplace must be wired with 110 VAC before installing this kit. See owners manual for details.

All wiring should be done by a qualified electrician and shall be in compliance with local codes and with the National Electric Code ANSI/NFPA No. 70- current (in the United States), or with the current CSA C22.1 CANADIAN ELECTRIC CODE (in Canada).

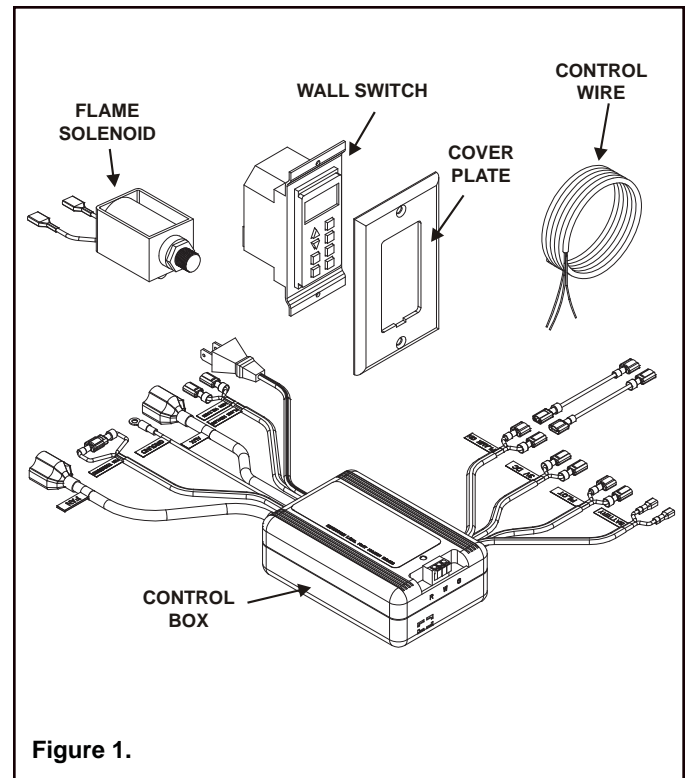

1.0 Installation instructions

1.1 Determine location

Determine the location for the wall switch. The chosen location should provide an accessible location in the same space as the gas fireplace. Never place this unit in a separate room. The control wire supplied with this switch is 33 ft (10m) in length for most models. The Cerna models ship with a 12 ft. (3.7m) length of control wire. The distance from the fireplace to the switch may be lengthened provided that the wire used never exceeds 50 ft, and that the distance from the fireplace to the switch never exceeds 30 ft.

The switch should be mounted into a listed electrical junction box. The junction box should be dedicated to this wall switch. Never install this wall switch into a junction box that is shared with other electrical service or devices. If possible, install this unit on an interior wall of the residence at a recommended height of 5 ft from the flooring. Should the switch be installed on an exterior wall, be certain wall insulation is kept intact and not damaged or dislodged during the installation of the electrical junction box.

For exterior wall installations, it is recommended that the junction box be sealed with caulking material. This will minimize heat loss through this location and improve the accuracy of the automatic (thermostat) operation.

	<p>⚠ WARNING</p> <p>Shock Hazard</p> <p>Do not provide any power to this unit until all wiring is completed. Failure to do so may destroy parts of this device and render it unusable, and may lead to possible electrical shock.</p>
	<p>Fire Hazard</p> <p>Modification of any parts or installation of damaged components will void the warranty, and you may possibly cause a fire hazard.</p>

1.2 Wiring the wall switch

Once a location is chosen and the electrical box is installed proceed as follows. Install the provided control wire from the fireplace to the switch location. (Control wire for Heatilator products is supplied with the fireplace). Use caution not to stress the wire around tight or sharp corners. Do not run the control wire adjacent to existing or future phone, data, cable, or electrical lines. The wire should not come into contact with any part of the fireplace exterior with the exception of where it exits the outer wrap. Feed the wire

to the electrical junction box and through a provided or approved strain relief. Using a screw driver, connect the red wire to the "R" terminal, the yellow or white wire to the "W" or "Y" terminal, and the green wire to the "G" terminal. Do not over-tighten. Using the screws provided, mount the switch to the electrical junction box right side up. Install provided cover plate using the screws provided. Do not use a substitute cover even though it may fit. The provided one is specifically designed for the automatic (thermostat) function of the unit.

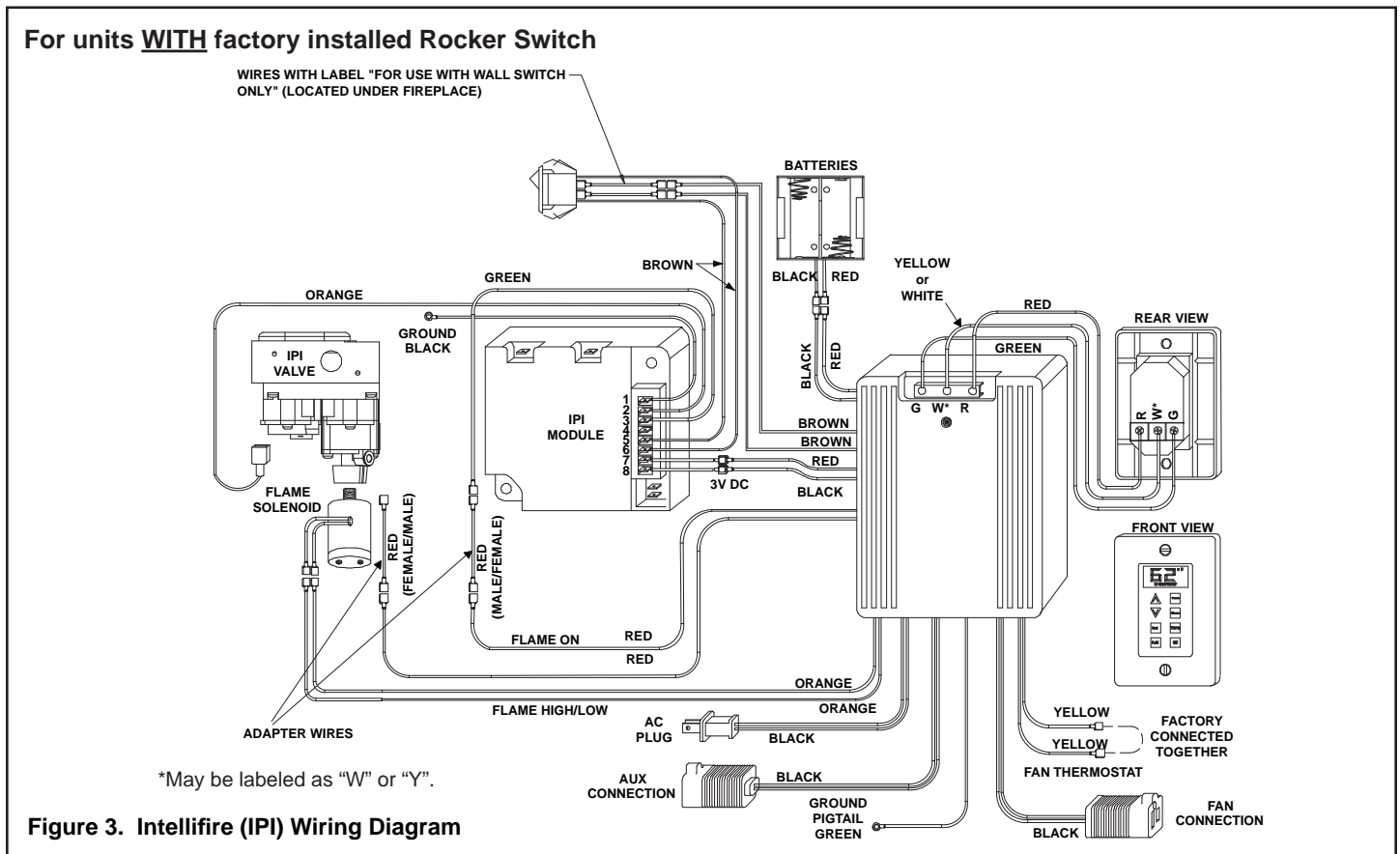
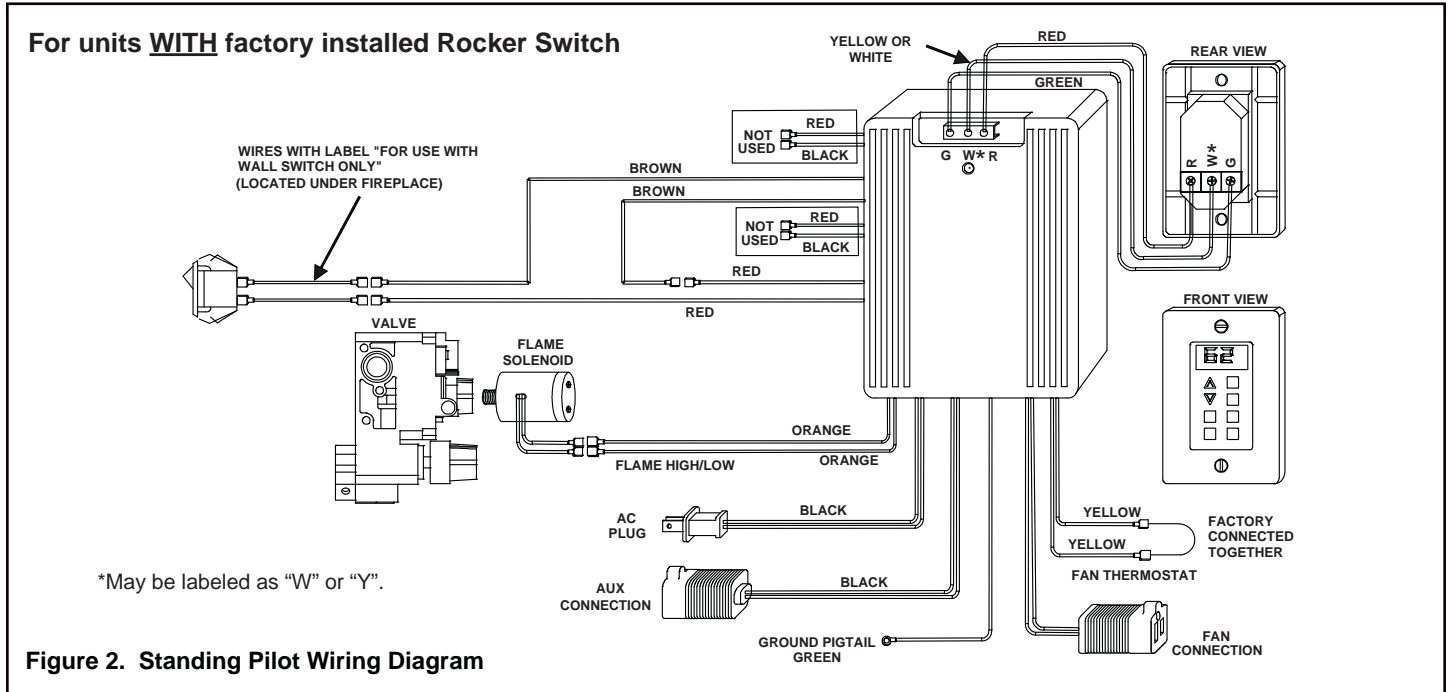

1.3 Installing the control box

⚠ CAUTION

- Do NOT install the control box when fireplace is hot.
- Do NOT plug control box in until all connections are complete.

1. Place control box into the base pan area of the fireplace. Place unit as close to the louvers or decorative front as possible and to either the left or right side.
2. Connect the red, yellow or white, and green wires to the appropriate labeled terminals on the control box.

For units WITH factory installed rocker switch.

3. Find the red and brown pigtail wire (labeled "FOR USE WITH REMOTE OR WALL SWITCH ONLY") which are attached to the fireplace ON/OFF rocker switch.

Standing Pilot Ignition: Connect these wires with the red and brown wires extending from control box (Fig 2).

Intellifire (IPI): Connect these wires with the brown wires extending from the control box (see Figure 3).

For units WITHOUT factory installed rocker switch.

Standing Pilot Ignition:

Find these parts packed with WSK-MLT:

- Rocker switch
- Rocker switch bracket
- Strips of Velcro
- Black and white wire pigtails - (2)
- Female ends (only used on Standing Pilot applications) - (2)

Cut male ends off black wires on each pigtail. Strip each end of wire approximately 1/4 inch. Slide each stripped wire into a female end and crimp. Slide rocker switch into bracket until it snaps into place. Attach end of each pigtail to each side of rocker switch. Find the top (brown) and bottom (red) wires from the control box and attach to white wires from rocker switch. Attach one black wire to the TH/TP side of gas valve and the other to the TH side of the gas valve. Attach the Velcro to the bottom of the rocker switch bracket and mount in a convenient location next to gas valve. (Refer to Figure 4).

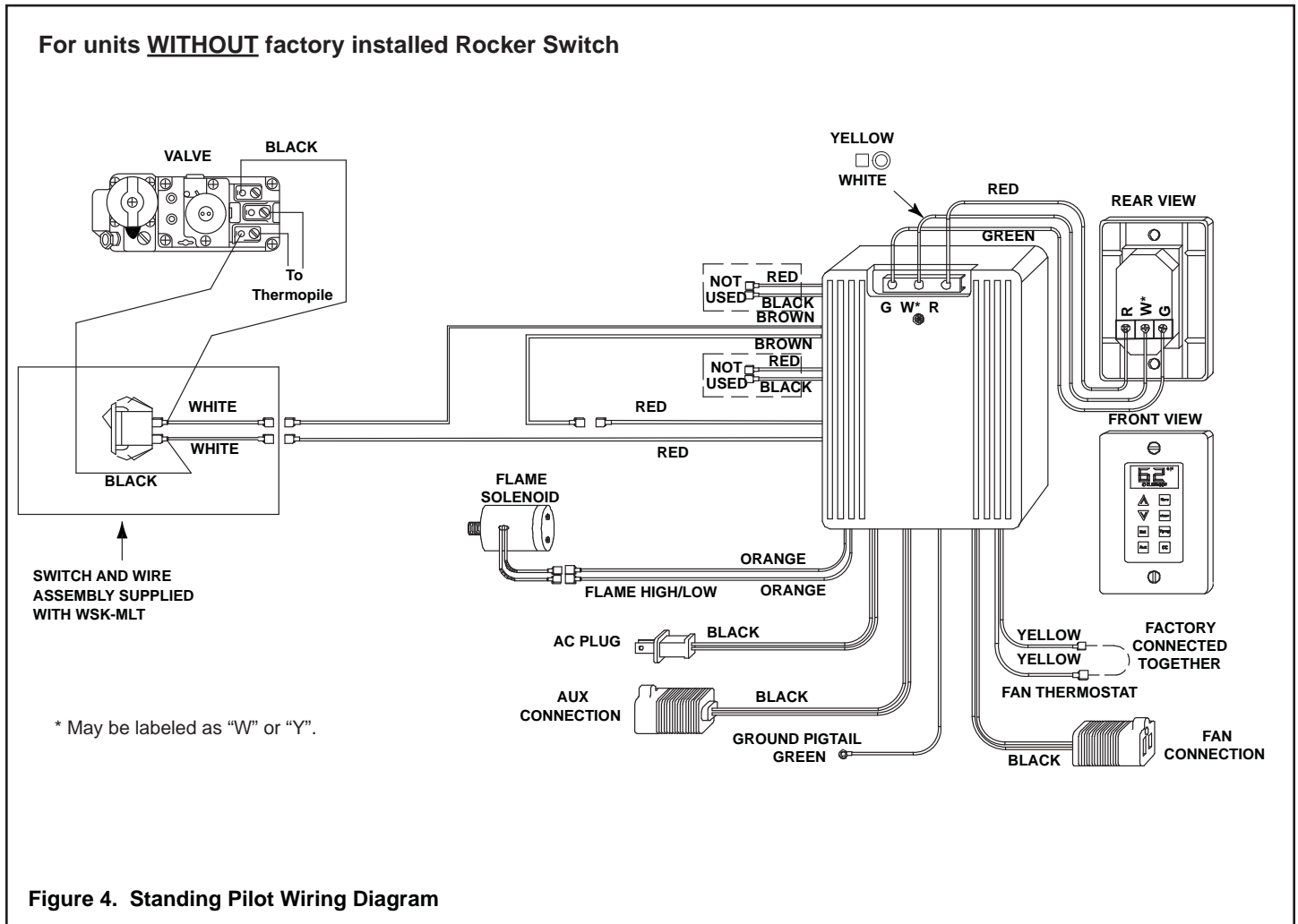

Figure 4. Standing Pilot Wiring Diagram

For units WITHOUT factory installed Rocker Switch

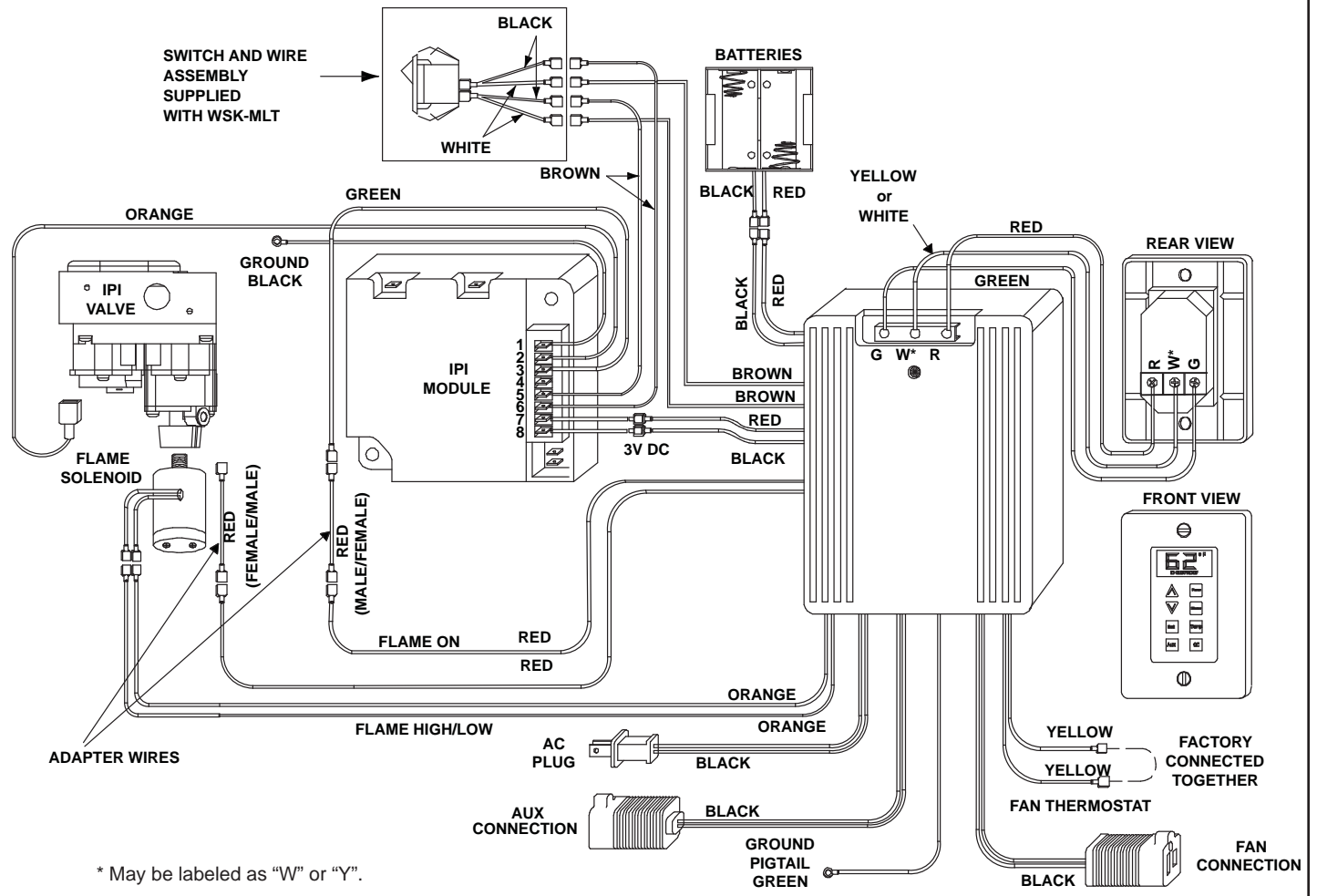

Figure 5. Intellifire (IPI) Wiring Diagram

Intellifire (IPI):

Find these parts packed with WSK-MLT:

- Rocker switch
- Rocker switch bracket
- Strips of Velcro
- Black and white wire pigtails - (2)
- Female ends (not used on IPI applications) - (2)

Slide rocker switch into bracket until it snaps into place. Attach one pigtail to one side of rocker switch and the other pigtail to the other side of the rocker switch. Find the two brown wires from IPI module and attach them to the two black wires from the rocker switch. Find the two brown wires from the control box and attach them to the white wires from the rocker switch. Attach the Velcro to rocker switch bracket and place rocker switch next to control box. (Refer to Figure 5).

Proceed to Step 4.

4. If equipped with a fan, plug the fan cord into the power cord labeled "FAN". Disconnect the two wires from the fan thermostat switch on the fireplace. Disconnect the two yellow wires from each other and connect them to the fan thermostat switch. Use one of the existing wires on the thermostat to connect to the proper end on the male terminated yellow wire.

Note: The fan rheostat has now been removed from the circuit and is inoperable. Use the wall switch to change fan speeds. The fan temperature sensor is still operable and will turn the fan on and off when the fireplace heats up and cools down.

5. Remove the screw and knob from the variable regulator and discard.
6. Unscrew the nut from the regulator and discard.
7. Remove the bag containing a washer and blue and red plungers from the side of the flame control solenoid.
8. Place washer on flame control solenoid (see Figure 6).

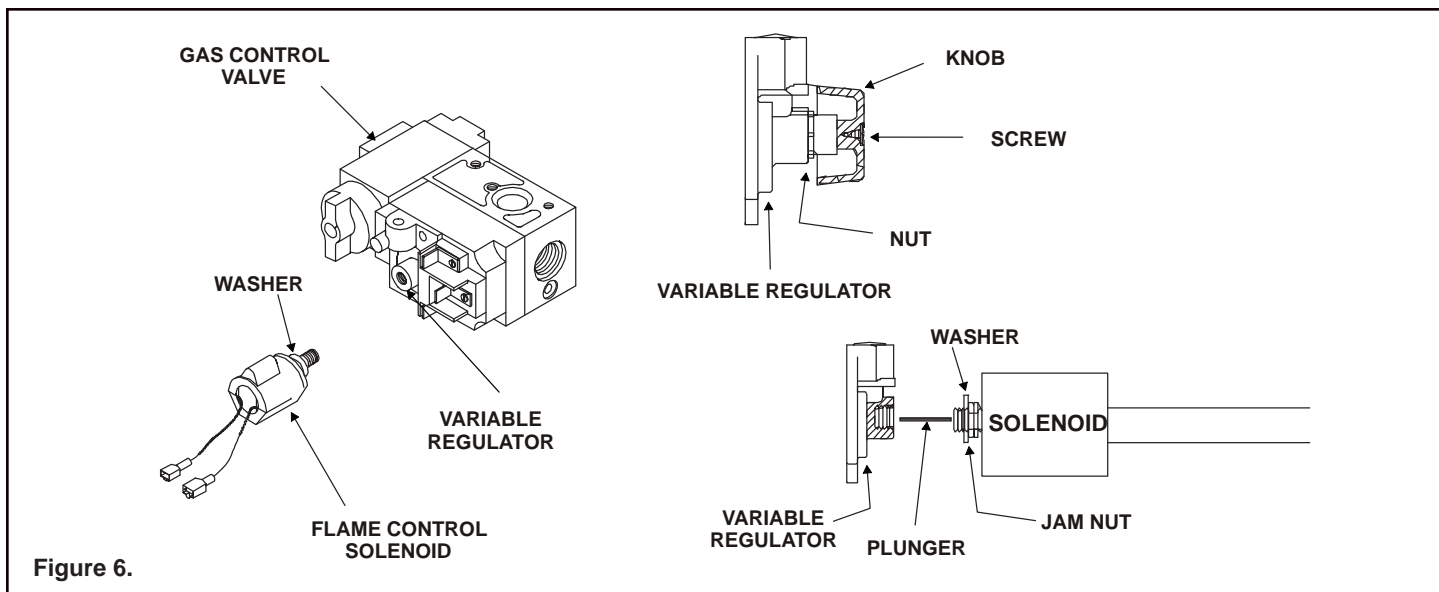

Figure 6.

9. Insert the correct plunger (blue - natural gas, red - propane) into the flame control solenoid (see Figure 6).
10. Thread the flame control solenoid with correct plunger into the thread hole in the variable regulator. Turn into valve approximately two full turns. Do not tighten or damage may occur.
11. Set the valve manifold pressure to the proper setpoint. The setpoint is adjusted by rotating the solenoid to adjust its depth into the valve. Using a manometer to monitor pressure, rotate the solenoid so that the output is set to proper range.
12. Tighten the jam nut on the threaded shaft of the solenoid against the valve regulator. Use an open-ended ½" wrench to tighten the nut, while holding the solenoid in the proper position. This step will ensure that the solenoid remains locked into the proper position.
13. Connect orange wires from control box to the flame control solenoid.
14. Ground the control box by attaching the green ground wire (has round ring-terminal on end) to the fireplace base pan or appropriate ground.

⚠ CAUTION

Lay the control box and wires flat on the base pan to avoid potential overheating problems.

13. Connect auxiliary functions. This unit is equipped with a 110 VAC supply cord (labeled "AUX") for controlling auxiliary functions such as an electric ember bed.

Intellifire (IPI) models only

For units with factory installed rocker switch see Fig. 3.

For units without factory installed rocker switch see Fig. 5.

14. Disconnect main valve wire (green) from the front of the valve. Connect red control wire to red adapter wire containing one large male end and one small female end and connect to valve terminal (see Figure 3). Connect the other red control wire to red adapter wire containing one large female end and one small male end and connect the green module wire (previously disconnected from valve front).
15. Carefully unplug battery pack wires from IPI module. Plug battery pack into red and black battery wires (labeled "Battery").
16. Plug red and black wires from control box (labeled "3V DC") to the red and black wires extending from IPI module (labeled "3V DC"). Red connects to red, black connects to black.

NOTE: Transformer supplied with the IPI system is NOT used. Disconnect the transformer from the electrical junction box. Transformer may be removed from the fireplace, but we recommend leaving it connected to the IPI module.

2.0 Operating Instructions

For units **WITH** factory installed rocker switch.

The ON/OFF rocker switch on the fireplace (located near the gas valve) must be in the "OFF" position for use with the WSK-MLT system. The ON/OFF rocker switch will NOT function with this device on Intellifire (IPI) models except during a power outage.

For units **WITHOUT** factory installed rocker switch.

The ON/OFF rocker switch now installed on the fireplace must be in the OFF position for use with the IPI or standing pilot system. The ON/OFF rocker switch will only be used to control the fireplace in a no-power condition. For standing pilot systems use the rocker switch to turn the fireplace on and off. When power is restored switch the rocker switch to OFF. For IPI system refer to "Operation Under Battery Power" for instructions.

After all connections are made and the control box is grounded, plug power cord into the fireplace junction box. The wall switch will be functional at this time.

NOTE: The temperature displayed by the wall switch may take up to 30 minutes to stabilize on initial power-up.

NOTE: Check control box and assure switch is in the "OFF" position. This switch is only used on Intellifire (IPI) control systems under battery operation.

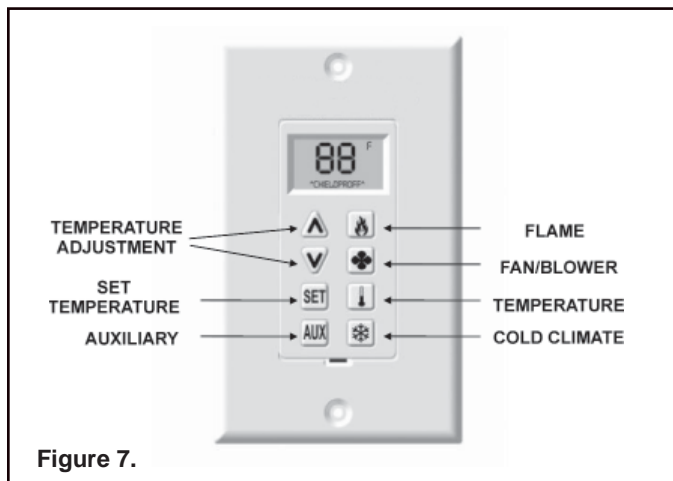

Figure 7.

2.1 Setting Flame Height/manifold pressure

(To be done by a qualified service technician). Upon initial power-up of this device, valve pressure must be set for flame adjustment.

- Loosen output pressure tap on valve and connect with pressure manometer.
- Press flame button once (Fig. 7); fireplace will light with flames on high.
- Turn solenoid clockwise to increase pressure, counter-clockwise to decrease pressure until manifold pressure on high is 3.5" water column for natural gas (NG), 10.0" water column for propane (LP).

- Once pressure is achieved spin jam-nut on solenoid stem tight against regulator face to prevent rotation. Do not overtighten.
- Press flame button twice to turn fireplace off.
- Remove manometer tube and tighten or close pressure tap. Use a soap solution to carefully check the pressure tap for leaks.

2.2 Wall Switch Button Operation

(Refer to Figure 7)

Flame Button

- Button Press: Unit On / Flames High, Turns on auxiliary power
- Button Press: Flames Low
- Button Press: Unit Off / Flames Off, Turns off auxiliary power

Fan / Blower Button

- Button Press: Fan High ("3")
- Button Press: Fan Medium ("2")
- Button Press: Fan Low ("1")
- Button Press: Fan Off



Temperature Button

- Button Press will toggle between Automatic and Manual Operation
- Press and Hold the button for 3 seconds to toggle between Fahrenheit and Centigrade Temperature Display.

Automatic Operation: Controller will monitor temperature and control unit according to the set point.

Manual Operation: Controller will not automatically change settings.

SET Set Temperature Button

- Button Press: Displays Set Point
- Use Up and Down Arrows to Adjust Set Point
- Press Set Button to Store New Set Point

Temperature Set Point can be adjusted between the ranges of: 45-90° Fahrenheit or 7-32° Centigrade

NOTE: The controller will turn off the fireplace at 2° F over set point and turn it back on at 2° F below set point.

Up and Down Arrows

- Push to adjust set point temperature under automatic control.

AUX Auxiliary Button

- Button Press: Turns on auxiliary power
- Button Press: Turns off auxiliary power

Can be operated independently of all functions.

Child Proof Mode

To Enter Child Proof Mode:

- Press the Up Arrow Button twice and Down Arrow Button once. The unit will send out 3 beeps and an indicator in the LCD panel will show that the child proof is on.

To Leave Child Proof Mode:

- Press the Up Arrow Button twice and Down Arrow Button once. The unit will send out 3 beeps and the indicator in the LCD panel that shows that the child proof is on will disappear.

NOTE: When in Child Proof Mode, only the arrow buttons will have functionality. Unit can enter Child Proof when the fireplace is on or off.

INTELLIFIRE (IPI) MODELS ONLY

❄️ Cold Climate Button

- Button Press: Turns on Climate Control
- Button Press: Turns off Climate Control

This allows the pilot flame to stay lit when activated, a benefit of this is reduced condensation on the glass at start-up in colder climate conditions.

Operation Under Battery Power

A switch on the control box allows for battery power under no-power conditions (see Figure 8). By controlling the power supply with this switch, the batteries are supplying power only when needed, thus extending battery life. The switch also provides a convenient means for switching to battery power should there be a loss of 110 VAC power to the control box.

- In the event of a power failure, switch the battery operation switch to the "Battery ON" position.
- The fireplace can now be turned on and off with the ON/OFF rocker switch located near the gas valve.
- The wall switch functions will not operate under battery power.
- Under battery control the only available function is flame "On" and "Off" in the high position.
- To maximize battery life, and to restore full function capability of the wall switch, flip switch to "OFF" position after 120 VAC power is restored.

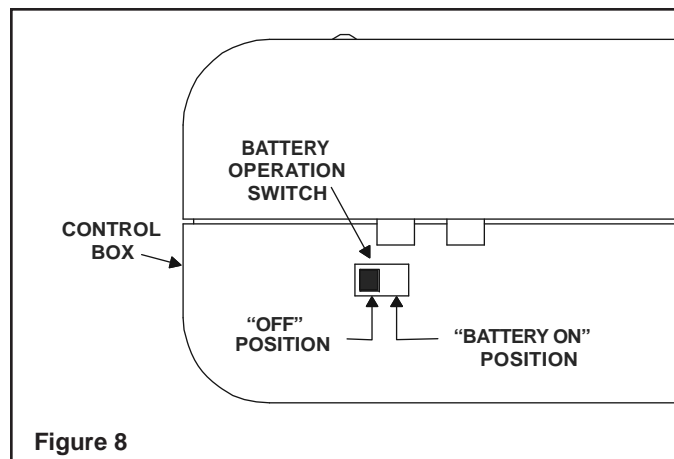

SERVICE PARTS LIST

DESCRIPTION	SERVICE PART NO.
SOLENOID	HTI-17-006
WALL SWITCH/KEY PAD	HTI-12-007
CONTROL WIRE	HTI-23-007
COVER PLATE	HTI-21-007
CONTROL BOX	HTI-13-007
ACTUATOR PINS	HTI-17-116
SWITCH KIT	HTI-25-007

Please contact your Hearth & Home Technologies dealer with any questions or concerns.

For the location of your nearest Hearth & Home Technologies dealer, please visit www.fireside.com.

Hearth & Home Technologies
7571 215th Street West, Lakeville, MN 55044
www.fireside.com